

HIGH PERFORMANCE ANCHORS



ROCNA[®]

Rock Solid.

VULCAN[®]

Fits for Power,
Sets for Safety.

CMP

CMP Group Ltd.

sales@cmpgroup.net | cmpgroup.net

MEET THE CREATOR



“The failings of the older designs no longer need to be tolerated, as the technology of anchors has simply evolved that little bit further. Far superior, and safer, anchoring performance may be expected. The new generation anchors can mean the old cliché that “newer is better” is, for once, true. That means better anchoring. And that means better cruising.”

ROCNA: CHANGING THE STATUS QUO

Legendary New Zealand sailor Peter Smith has been designing, building, and sailing racing and cruising boats since the early 1960's. With over 150,000 nautical miles of cruising, Pete experienced the same anchoring problems that are still prevalent today – needing to carry a variety of anchors to suit various seabeds, yet still the anchors dragged and boaters felt insecure.

He designed the Rocna and then the Vulcan anchors to solve these problems once and for all. We believe your anchor should provide you and your crew with reliability, security, and confidence. That's why our anchors are easy to use, set instantly on most seabeds, and provide rock solid holding power for ultimate peace of mind. “Your anchor should provide you and your crew with reliability, security, and confidence,” says Peter.

AN INDEPENDENTLY TESTED NEW GENERATION DESIGN

Rocna consistently returns top results in objective and independent testing. Since its launch in 2004, the Rocna has led worldwide anchor tests as published in the likes of SAIL, Yachting Monthly, Practical Boat Owner, Voile, and others. Because of the Rocna's reliable and convincing performance against its competition, Rocna is trusted to be rock solid in the real world.

VULCAN: IN THE FOOTSTEPS OF ROCNA

The new Vulcan anchor is the first major design development since the launch of Rocna anchor itself. Following on the success of the Rocna, designer Peter Smith was often approached by customers seeking to experience the exceptional holding power and setting performance of a Rocna, but who had difficulties accommodating the roll-bar design on their bow.

After years of testing and development, Peter has come up with a design that meets the needs of these customers – the Vulcan.

GUARANTEED FOR LIFE

Each Rocna anchor comes with a **LIFETIME WARRANTY** against both breakage and bending in addition to manufacturing defects. Refer to our website www.rocna.com for details.

ROCK SOLID **ROCNA**[®]

CHOOSE THE ROCNA:

- For the best multi-purpose anchor that sets on all ocean floors.
- For vessels of all sizes, from small runabouts to super-yachts, workboats, and small ships.

FINISH: Stainless Steel or Galvanized

SIZES: 4 kg – 275+ kg (9 lb – 606+ lb)

PRECISION SETTING

The roll-bar (**A**) ensures that the anchor always arrives at the ideal angle for penetration, and the setting skids (**B**) guide the fluke tip (**C**), which acts as a sharp chisel cutting into the seabed. With a third of the anchor's weight on its fluke tip, an instant reliable set is ensured with every use.

ROCK SOLID HOLDING POWER

Of all anchor types, a concave fluke (**D**) gives the greatest resistance, and through clever design Rocna provides the largest fluke area possible. In very soft seabeds, this provides the holding power to secure your boat. On hard or weedy sea floors, Rocna's chisel tip (**C**) ensures that it cuts through and bites deep.

MAXIMUM VERSATILITY

The Rocna is a true multi-purpose anchor that sets and holds in most seabeds, from soft mud to hard sand, clay, grass, and kelp.

Tandem anchor attachment point

FEATURES OF THE ROCNA:

- **Quick sets across a range of bottom types**
- **Rock solid holding power**
- **Resistant to wind and tide shifts**
- **Self-launching**
- **Tandem anchoring attachment point**
- **Guaranteed for life**

RESISTANT TO WIND AND TIDE SHIFTS

A Rocna remains stable and buried, and doesn't roll out on reversal or veering of load, or if dragged beyond yield, providing enhanced security.

HIGHEST QUALITY BUILD AND FINISH

Compare the welds and finish on a genuine Rocna anchor to alternatives. We believe a top performing product should be built like one, and we spend a lot of time and resources on production and quality control procedures to ensure that this is the case.

HIGH TENSILE STEEL SHANK (E)

Rocna anchors are designed – and built – for strength and durability.

SELF-DEPLOYING AND SELF-RECOVERING

The Rocna shank is designed so the anchor self-launches and self-stows on the majority of bow-rollers, with the greatest possible reliability.

Buoyed retrieval line attachment point

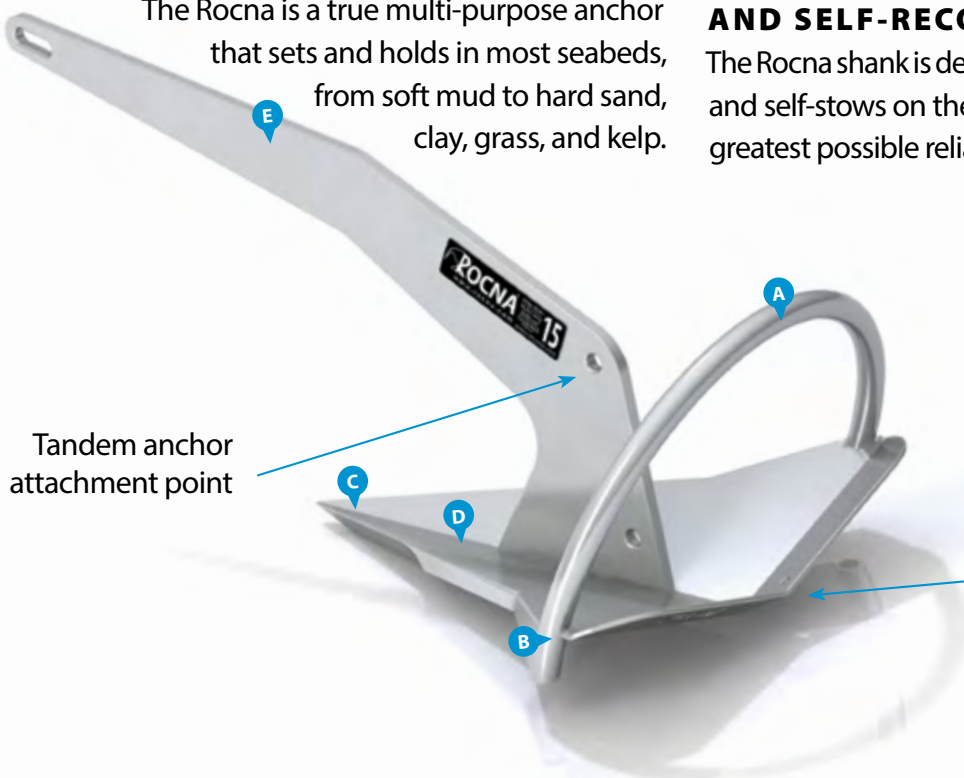

FITS FOR POWER, SETS FOR SAFETY **VULCAN**



FEATURES OF THE VULCAN:

- **Compatible with the most boats**
- **Quick sets across a range of bottom types**
- **Rock solid holding power**
- **Self-launching**
- **Resistant to wind and tide shifts**
- **Guaranteed for life**

NEW SOLUTIONS FOR OLD CHALLENGES

The Vulcan features a unique combination of shank and fluke geometry – including an innovative roll-palm™ (**A**) at the rear of the fluke – which self-rights the anchor on the seabed without the use of a roll-bar. This is assisted by the V-bulb™ (**B**) which extends fluke ballast downward to gain maximum leverage and efficiency. This development permits a larger fluke surface area than competing designs which rely on simple dead weight, while the concave fluke (**C**) is similar in design to the Rocna, directly equating to more holding power and security.

FIT FOR ALL VESSELS AND THEIR OPERATORS

The omission of a roll-bar along with a carefully designed shank profile (**D**) ensures a snug fit on the bows of a widely expanded range of vessels. Platforms, bowsprits, prods, stays, and other protrusions are easily cleared with no hassle or inconvenience.

UNIVERSAL APPEAL

The Vulcan is carefully designed to offer the greatest possible compatibility across a wider range of vessel bow configurations, particularly powerboats with a bow pulpit. It brings the security and reliability of the Rocna anchor, highly successful and popular with off-shore cruisers and adventurers, to a wider range of boaters who require improved anchoring performance.

CHOOSE THE VULCAN:

- For a snug fit on the bows of any boat, including those with platforms and bow sprits for vessels from small runabouts to large yachts and powerboats.

FINISH: Stainless Steel or Galvanized

SIZES: 4 kg – 55 kg (9 lb – 121 lb)

SMOOTH BOW INTERACTION & COMPATIBILITY

The Vulcan's shank shape (**D**) encourages the self-launching and self-stowing upon retrieval on the majority of bow rollers, with a liquid smooth action, ensuring ease of use for all operators.

STRENGTH FROM SOPHISTICATED DESIGN

In addition to the use of high tensile steel, shank strength is optimized by a unique I+V profile™ shank design (**E**), granting improved resistance to bending courtesy of a computer optimized I-beam geometry. This visually elegant innovation also improves setting performance, with the lower V edge (**F**) cutting into the seabed and minimizing resistance to a deep and secure burial.

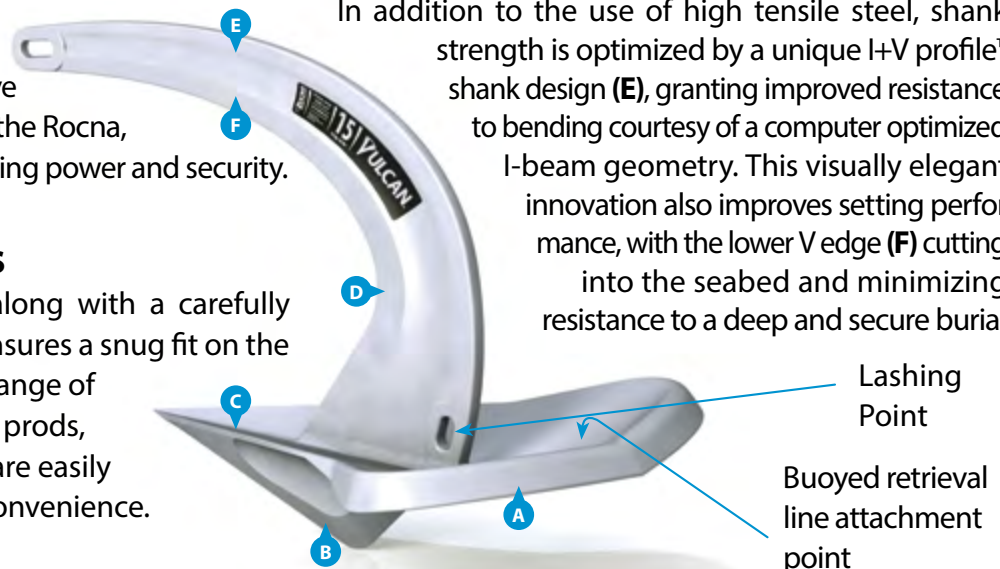

SIZING FOR YOUR BOAT



WHAT SIZE ANCHOR DO I NEED?

Please find our sizing chart for Rocna and Vulcan anchors below, attached to anchors in stores, or on our website: rocna.com

WHICH WILL FIT BEST, ROCNA OR VULCAN?

The Rocna anchor has "set the bar" for the highest performance and reliability when put to the test. The Vulcan infuses as many as possible of the proven performance advantages of its elder sibling, while being

specifically designed to fit a wider range of vessels. For the Vulcan, the omission of a roll-bar along with a carefully designed shank prole ensures a snug fit on bows. Platforms, bowsprits, prods, stays, and other protrusions are easily cleared.

ROCNA AND VULCAN SIZING

There's a Rocna or Vulcan to suit just about any vessel – including larger sizes not featured here. 1 t = 1000 kg (metric tonnes). We base our calculations on 50 knots of wind, associated surge, and poor holding bottoms. For more on our philosophy and rationale, please consult The Rocna Knowledge Base at www.kb.rocna.com/kb. For multi-hulls: use the chart as instructed, then select the model one size larger.

		ROCNA OR VULCAN MODEL												
		4	6	9	10	12	15	20	25	33	40	55	70	110
				Vulcan only	Rocna only	Vulcan only							Rocna only	Rocna only
Vessel length	4 m 13 ft	≤ 2 t												
	5 m 16 ft	≤ 1 t	≤ 5 t											
	6 m 20 ft	≤ ½ t	≤ 3.5 t	≤ 7 t										
	7 m 23 ft	≤ ½ t	≤ 2 t	≤ 6 t	≤ 7 t	≤ 9 t								
	8 m 26 ft		≤ 1 t	≤ 5 t	≤ 6 t	≤ 8 t	≤ 12 t							
	9 m 30 ft		≤ ½ t	≤ 4 t	≤ 5 t	≤ 7 t	≤ 10 t	≤ 16 t						
	10 m 33 ft			≤ 3 t	≤ 4 t	≤ 6 t	≤ 8.5 t	≤ 14 t	≤ 22 t					
	11 m 36 ft			≤ 2 t	≤ 3 t	≤ 5 t	≤ 7 t	≤ 12 t	≤ 20 t					
	12 m 39 ft					≤ 4 t	≤ 6 t	≤ 10 t	≤ 18 t	≤ 30 t				
	14 m 46 ft						≤ 4 t	≤ 6 t	≤ 13 t	≤ 23 t	≤ 40 t			
	16 m 52 ft							≤ 3 t	≤ 9 t	≤ 18 t	≤ 32 t	≤ 60 t		
	18 m 59 ft								≤ 5 t	≤ 14 t	≤ 25 t	≤ 50 t	≤ 85 t	
	20 m 66 ft									≤ 10 t	≤ 18 t	≤ 40 t	≤ 75 t	≤ 165 t
	22 m 72 ft									≤ 6 t	≤ 12 t	≤ 33 t	≤ 65 t	≤ 150 t
	24 m 79 ft										≤ 7 t	≤ 25 t	≤ 55 t	≤ 135 t
	26 m 85 ft											≤ 18 t	≤ 45 t	≤ 120 t
	28 m 92 ft												≤ 35 t	≤ 105 t
30 m 98 ft													Use EN*	
35 m 115 ft														Use EN*
Anchor weight	4 kg	6 kg	9 kg	10 kg	12 kg	15 kg	20 kg	25 kg	33 kg	40 kg	55 kg	70 kg	110 kg	
	9 lb	13 lb	20 lb	22 lb	27 lb	33 lb	44 lb	55 lb	73 lb	88 lb	121 lb	154 lb	243 lb	
Rocna fluke area	460 cm ²	590 cm ²	-	795 cm ²	-	1030 cm ²	1140 cm ²	1415 cm ²	1695 cm ²	1945 cm ²	2300 cm ²	2690 cm ²	3330 cm ²	
Vulcan fluke area	420 cm ²	560 cm ²	730 cm ²	-	880 cm ²	1020 cm ²	1240 cm ²	1440 cm ²	1730 cm ²	1970 cm ²	2430 cm ²	-	-	
Recommended G40 chain	6 mm	6 mm	7 mm	7 mm	8 mm	8 mm	9 mm	10 mm	10 mm	11 mm	12 mm	14 mm	16 mm	
	1/4"	1/4"	1/4"	1/4"	5/16"	5/16"	5/16"	3/8"	3/8"	7/16"	7/16"	1/2"	5/8"	

Vessel displacement units: 1 t (metric tonne) = 2,205 lb

Vessel displacement units: 1 t (metric tonne) = 2,205 lb

(*) Classification Rules sizing

Rocna anchors from size 110 kg (243 lb) and above may be sized based on classification society Rules for SHHP anchors.

Modern rules permit a mass 33% lighter than HHP types, or 50% lighter than "standard stockless" types. Anchor sizing is based on a vessel's separately calculated Equipment Number (EN). For more information, please consult the Rocna Knowledge Base articles on our sizing recommendations and Classification and Certification.

	Equipment Number (EN) range (applies to Lloyd's, RINA)				
	50-70	70-110	110-130	130-175	>175
Rocna model	110	150	200	275	Please enquire
Anchor weight	110 kg	150 kg	200 kg	275 kg	
	243 lb	331 lb	441 lb	606 lb	
Fluke surface area	2300cm ²	4470 cm ²	5560 cm ²	6510 cm ²	

CONFIRM FIT ON YOUR BOAT

ROCNA DIMENSIONS:

Model	Weight		Fluke area		ROCNA															
					A		B		C		D		E		F		S		Width	
	kg	lb	cm ²	in ²	mm	inch	mm	inch	mm	inch	mm	inch	mm	inch	mm	inch	mm	inch	mm	inch
4	4	9	460	71	547	21.5	234	9.2	154	6.1	133	5.2	96	3.8	103	4.1	75	3.0	275	10.8
6	6	13	590	91	630	24.8	270	10.6	170	6.7	150	5.9	102	4.0	123	4.8	80	3.1	315	12.4
10	10	22	795	123	724	28.5	312	12.3	204	8.0	174	6.9	130	5.1	133	5.2	90	3.5	365	14.4
15	15	33	1030	160	830	32.7	360	14.2	235	9.3	205	8.1	145	5.7	156	6.1	100	3.9	415	16.3
20	20	44	1140	177	864	34.0	373	14.7	244	9.6	220	8.7	162	6.4	158	6.2	110	4.3	435	17.1
25	25	55	1415	219	971	38.2	420	16.5	275	10.8	233	9.2	175	6.9	184	7.2	115	4.5	485	19.1
33	33	73	1695	263	1066	42.0	485	19.1	280	11.0	254	10.0	180	7.1	206	8.1	120	4.7	532	20.9
40	40	88	1945	301	1142	45.0	520	20.5	300	11.8	278	10.9	188	7.4	224	8.8	130	5.1	570	22.4
55	55	121	2300	357	1235	48.6	560	22.0	323	12.7	306	12.0	225	8.9	226	8.9	150	5.9	620	24.4
70	70	154	2690	417	1338	52.7	607	23.9	354	13.9	330	13.0	240	9.4	250	9.8	155	6.1	670	26.4
110	110	243	3330	516	1490	58.7	675	26.6	390	15.4	352	13.9	265	10.4	286	11.3	180	7.1	745	29.3
150	150	331	4630	718	1725	67.9	779	30.7	449	17.7	416	16.4	318	12.5	317	12.5	203	8.0	867	34.1
200	200	441	5905	915	1901	74.8	859	33.8	494	19.4	462	18.2	349	13.7	351	13.8	224	8.8	953	37.5
275	275	606	6690	1037	2143	84.4	967	38.1	558	22.0	517	20.4	394	15.5	394	15.5	253	10.0	1049	41.3

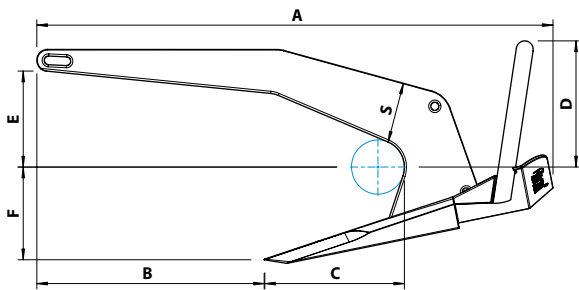

VULCAN DIMENSIONS:

Model	Weight		Fluke area		VULCAN														
					A		B		C		D		E		S		Width		
	kg	lb	cm ²	in ²	mm	inch	mm	inch	mm	inch	mm	inch	mm	inch	mm	inch	mm	inch	mm
4	4	9	430	67	472	18.6	142	5.6	145	5.7	46	1.8	119	4.7	67	2.6	258	10.2	
6	6	13	560	87	541	21.3	163	6.4	167	6.6	53	2.1	136	5.4	77	3.0	296	11.6	
9	9	20	730	113	619	24.4	186	7.3	191	7.5	61	2.4	156	6.1	88	3.5	339	13.3	
12	12	27	890	138	681	26.8	205	8.1	210	8.3	67	2.6	172	6.8	97	3.8	373	14.7	
15	15	33	1030	160	734	28.9	221	8.7	226	8.9	72	2.8	185	7.3	104	4.1	402	15.8	
20	20	44	1250	194	808	31.8	243	9.6	249	9.8	79	3.1	204	8.0	115	4.5	442	17.4	
25	25	55	1450	225	870	34.3	262	10.3	268	10.6	85	3.4	220	8.6	124	4.9	476	18.7	
33	33	73	1740	270	955	37.6	287	11.3	294	11.6	93	3.7	241	9.5	136	5.3	522	20.6	
40	40	88	1980	307	1018	40.1	306	12.1	313	12.3	100	3.9	257	10.1	145	5.7	557	21.9	
55	55	121	2450	380	1132	44.6	340	13.4	349	13.7	111	4.4	286	11.2	161	6.3	619	24.4	

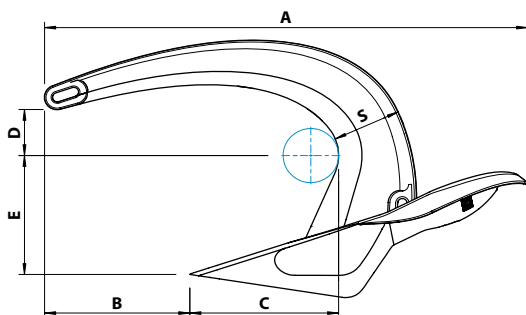

*The descriptions and guidelines shown in this literature should be used as a general reference only. For any further technical information please contact our Technical Service.

Contents of this Brochure/ Catalogue are based on the latest information available at the time of publication. CMP/ Rocna assumes no responsibility for the accuracy of the information contained herein. Product specifications are subject to change without notice.

CONFIRM FIT ON YOUR BOAT

HOW DO I CONFIRM A ROCNA OR VULCAN ANCHOR WILL FIT MY VESSEL?

To ensure that your new Rocna or Vulcan anchor will fit well on your boat's bow, there is a number of resources to assist you:

- **CHECK OUR KNOWLEDGE BASE**

The **Rocna Knowledge Base** features a large and ever-growing collection of "boat fit cases" under Rocna bow compatibility at:

www.kb.rocna.com/kb

Many popular production boats are included along with photos and other information relevant to the fitting of a Rocna anchor. If other owners have successfully fitted a Rocna or Vulcan, you may purchase with confidence.

Also included are articles and recommendations on the topic of bow roller assembly design.

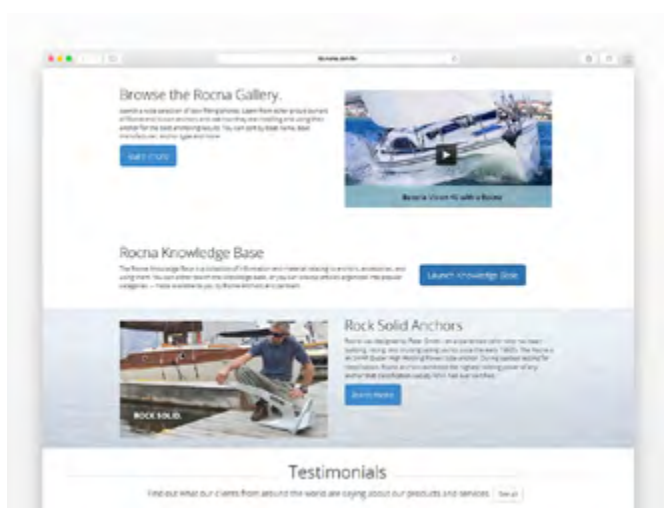

- **CONFIRM BASIC DIMENSIONS**

Measurements important to the fitting of the anchor on a bow roller are reproduced in this brochure, and may also be downloaded at:

www.rocna.com/distributable/patterns

Using these drawings and a tape measure, many boaters can easily determine that a Rocna or Vulcan will fit their boat.



- **GET THE FULL-SCALE PATTERNS**

A 2D side-profile of any size anchor may be produced by using the full scale patterns available at:

www.rocna.com/distributable/patterns

The pattern may be printed on any standard printer on A4 or letter paper, then assembled to form a full scale mock-up.

You may use these patterns to evaluate a fit that may be more difficult to determine just from the basic dimensions on this sheet.

- **REQUEST 3D OR 2D CAD FILES**

We are able to supply naval architects or boat builders with accurate CAD files of all Rocna and Vulcan models to support the proper integration of the anchor into a boat's ground tackle system.

Contact us at support@rocna.com, and with the execution of a simple terms of use agreement these CAD files may be made available.

READ THE TESTIMONIALS

"I wanted to share an email with you that we sent to our friends and family while we were cruising from Miami, FL to St Thomas, Virgin Islands when we were attacked by Hurricane Sandy with recorded winds of 126 mph on the bow of our boat while we held fast with our 40 kg Rocna anchor. Below is an accounting of what happened and how great our Rocna anchor performed.

Reports over the radio say the winds are estimated to be 110-125 mph and getting stronger by the minute while the rain is getting heavier by the second...

For the next hour we watch branches and trees flying past us in the wind. Boats breaking loose, the lucky ones get washed onto the beach, the unlucky ones get washed onto the rocks where they begin a slow crunching death, and other boats, we watch in silence as they get swept out of the mouth of

the cove out to sea into waves bigger than you can imagine while disappearing into the gray, rainy haze... We have a bridle that leads to our 180' of rode, which is attached to our 60' of chain, which is attached to our 40 kg Rocna anchor, which must have buried itself 2-3 feet deep by now with all this force pulling against it.

29 people died in the Caribbean yesterday from FrankenStorm but none of them were us. We woke up this morning and gave a shuttle ride to the lobster boat guys who let us use their mooring as a backup, but we never needed it as the Rocna held firm through it all... We told them that instead of using 3 different anchors, with one of them weighing 150 lbs, all they really needed was one Rocna."

Frederic & Barbie, Rocna 40 on Meridian 391

To read more go to: www.rocna.com/reviews/testimonials



ROCK SOLID CREDENTIALS: DON'T TAKE OUR WORD FOR IT

Of course we think the Rocna and Vulcan anchors are exceptional, but you don't need to just take our word for it. Since its release in 2004 the Rocna has been independently tested by numerous authorities over the world. And the Vulcan inherits the same successful fluke geometry of its elder sibling.

So, if you're not convinced yet, why not visit our website rocna.com that shows a number of independent reviews and comments from the internationally renowned boating experts such as Jimmy Cornell, Steve Dashew, Jérôme Poncet, Bill Parlatore, and others. You will also find numerous comparison tests from leading magazines like Yachting Monthly, SAIL magazine, and Practical Boat Owner where Rocna is consistently a top performer. We'll let the results speak for themselves.

Rocna Anchors are manufactured by CMP Group Ltd.

7733 Progress Way, Delta, BC, Canada, V4G 1A3 | Tel: 1 (604) 940-2010 | Fax: 1 (604) 952-2650

www.rocna.com • enquiries@rocna.com

[f @rocna](https://www.facebook.com/rocna) [@rocna_anchors](https://www.instagram.com/rocna_anchors)